

## **General Auger Feeding Systems**

Replacement Parts Guide

INST. No. 11-00-0674 08-21

# Notes, Warnings, and Cautions



This manual contains **Notes, Warnings and Cautions** in addition to the assembly instructions.

**Notes:** Provide additional comments to help with installation and set up.



**CAUTIONS:** Provide notification of situations that can cause damage to machinery and tools.



**WARNINGS!** Provide alerts to situations that can cause personal injury or death.

Please take the time to read and understand this manual before beginning assembly. **CAREFULLY FOLLOW THE SAFETY AND OPERATING INSTRUCTIONS in this manual.** Observe the following precautions when working on or near the machinery:

- Understand the limitations and hazards associated with operating this equipment before using.
- Wear appropriate eye protection when assembling and using this equipment .
- Do not wear loose clothing, jewelry, etc.
- Keep sleeves rolled above the elbows.
- Confine long hair.
- Always wear approved protective footwear.

**MAKE SURE ALL PERSONNEL UNDERSTAND THE POTENTIAL DANGER** of someone getting too close or trying to make repairs or adjustments while the machine is running. This equipment has several **AREAS WHERE INJURIES COULD OCCUR IF GUARDS OR COVERS ARE REMOVED. KEEP ALL COVERS AND GUARDS IN PLACE WHILE EQUIPMENT IS IN OPERATION.**

Observe the following precautions when servicing the machinery:

- Do not remove guards except when performing maintenance.
- Do not operate the machine with guards or covers removed.
- When performing maintenance or repairs make sure the local control switch is **OFF** and the main power control panel is **OFF** and tagged “**DO NOT OPERATE.**”
- Make all adjustments with the power **OFF**.
- **NEVER** reach into the machine while the system is operating, keep hands out of the machine chain and belt areas. Keep all guards and covers in place when power is on.
- Work carefully and give the work you are doing your undivided attention. Do not look away, talk or play around. Careless acts can cause **SERIOUS INJURY.**

# Contents

NOTES, WARNINGS, AND CAUTIONS .....	2
1 GEAR DRIVE UNIT 358 RPM, 1/2 HP.....	4
2 GEAR DRIVE UNIT 657 RPM, 1 HP.....	5
3 GEAR DRIVE UNIT WITH C-FACE MOTOR .....	6
3.1 Gear Drive Unit with C-Face Motor Parts List.....	7
4 BELT DRIVE UNIT PART NO.11-00-0488 .....	8
4.1 Belt Drive Unit Part No.11-00-0488 Parts List .....	9
5 CONTROL PAN .....	10
5.1 Control Pan Parts List.....	11
5.2 Control Pan (continued) .....	12
5.3 Control Pan Parts List.....	13
5.4 Control Pan (continued) .....	14
5.5 Control Pan (continued) .....	15
6 INSTALL RESTRICTOR PLATE STEPS.....	16
7 INTERMEDIATE CONTROL PAN PART NO. 86-00-2764.....	18
7.1 Intermediate Control Pan-Parts List .....	19
8 FLUXX® INTERMEDIATE CONTROL PAN.....	20
8.1 Fluxx® Intermediate Control Pan Parts List .....	21
9 FLUXX® END CONTROL PAN .....	22
9.1 Fluxx® End Control Pan-Parts List.....	23
10 ONE-WAY HOPPER PART NO. 11-01-1133 .....	24
11 TWO-WAY HOPPER PART NO. 11-02-1345.....	25
12 HOPPER EXTENSION.....	26
INDEX.....	27

# 1 Gear Drive Unit 358 RPM, 1/2 hp

## Power Unit 86-01-1050

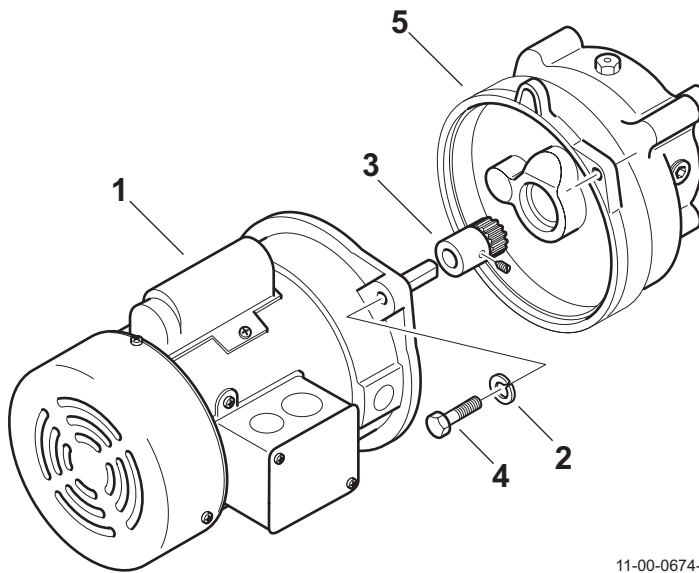

11-00-0674-01

Item No.	Part No.	Description
1	86-00-3864	MTR, 1/2HP, 1PH, 60HZ, 48Y, 115/230V, 1725RPM, TEFC, TP
2	90-20-0054	5/16 in. Lock Washer
3	10-00-9613	Pinion
4	99-10-0109	5/16-18 x 1-1/4 in. Hex Bolt
5	86-00-2661	REDUCER, TOLEDO, 358RPM, BLUE ALUM CASE, (INCLUDES VENT PLUG 11

# 2 Gear Drive Unit 657 RPM, 1 hp

## Power Unit 86-01-1062

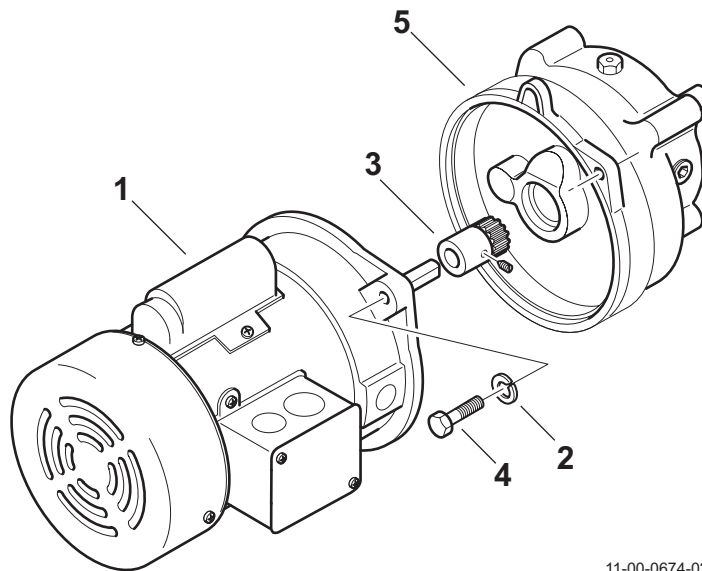

11-00-0674-02

Item No.	Part No.	Description
1	90-00-0366	1 HP, 50/60HZ, 1PH, 230V Motor
2	99-20-0054	5/16 in. Lock Washer
3	86-00-0205	PINION 14T x 5/8" x 2.245L
4	99-10-0109	5/16 - 18 x 1 1/4 in. Hex Bolt
5	86-00-2663	REDUCER, TOLEDO, 657RPM, ALUM M164--GE, L/1614-MX5 INCLUDES VENT

# 3 Gear Drive Unit with C-Face Motor

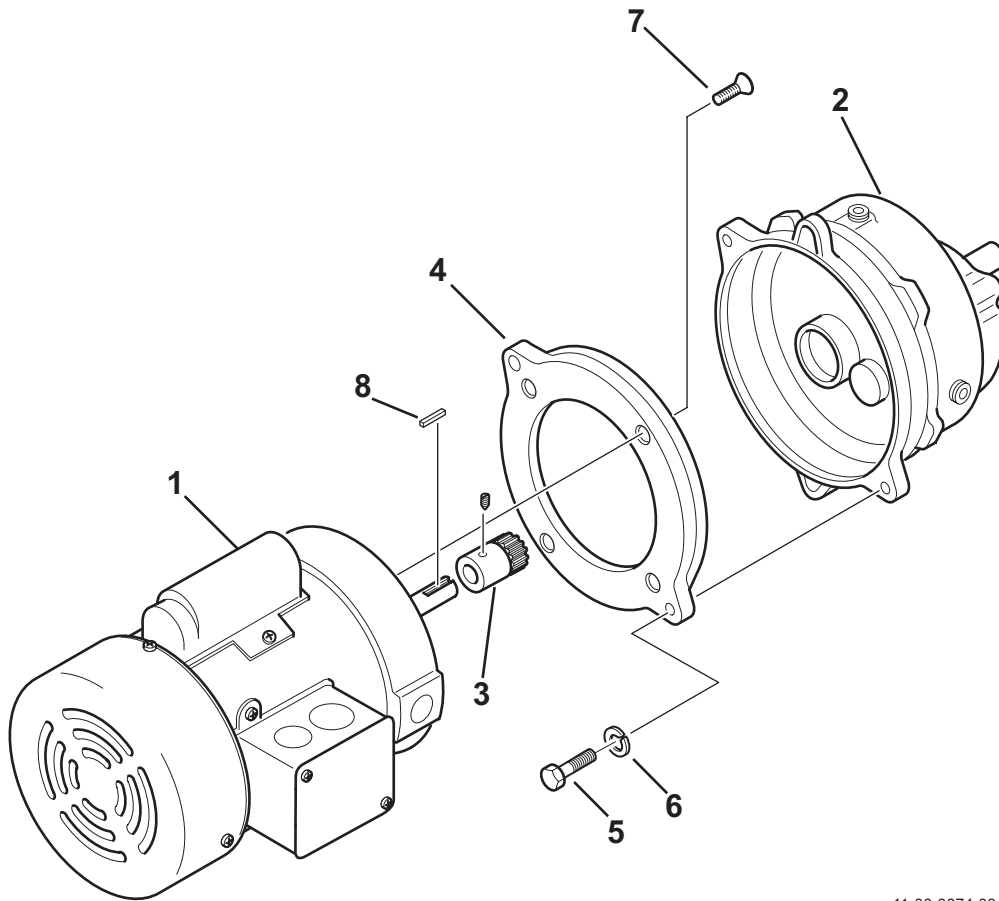

11-00-0674-03

## 3.1 Gear Drive Unit with C-Face Motor Parts List

	1	2		
PWR Unit	Motor	Reducer	Description	RPM
11-00-0533	90-00-0484	86-00-2661	1/2HP, 60HZ, 3PH, 230V	358
11-00-0779	90-00-9069	86-00-2663	1 HP, 60HZ, 3PH, 208-230V/460V	657
11-00-0780	90-00-0462	86-00-2663	1 HP, 60HZ, 3PH, 380V	657
11-00-0530	90-00-0449	86-00-2661	1/2HP, 50HZ, 3PH, 380V	300

Item No.	Part No.	Description
3	11-00-9364	Pinion
4	11-00-1053	Motor Adapter
5	99-10-0109	5/16 - 18 x 1 1/4 in. Hex Bolt
6	99-20-0054	5/16 in. Lock Washer
7	99-10-1216	3/8 - 16 x 3/4 in. Flat Head Screw
8	99-50-0338	3/16 3/4 in. Square Key

# 4 Belt Drive Unit Part No.11-00-0488

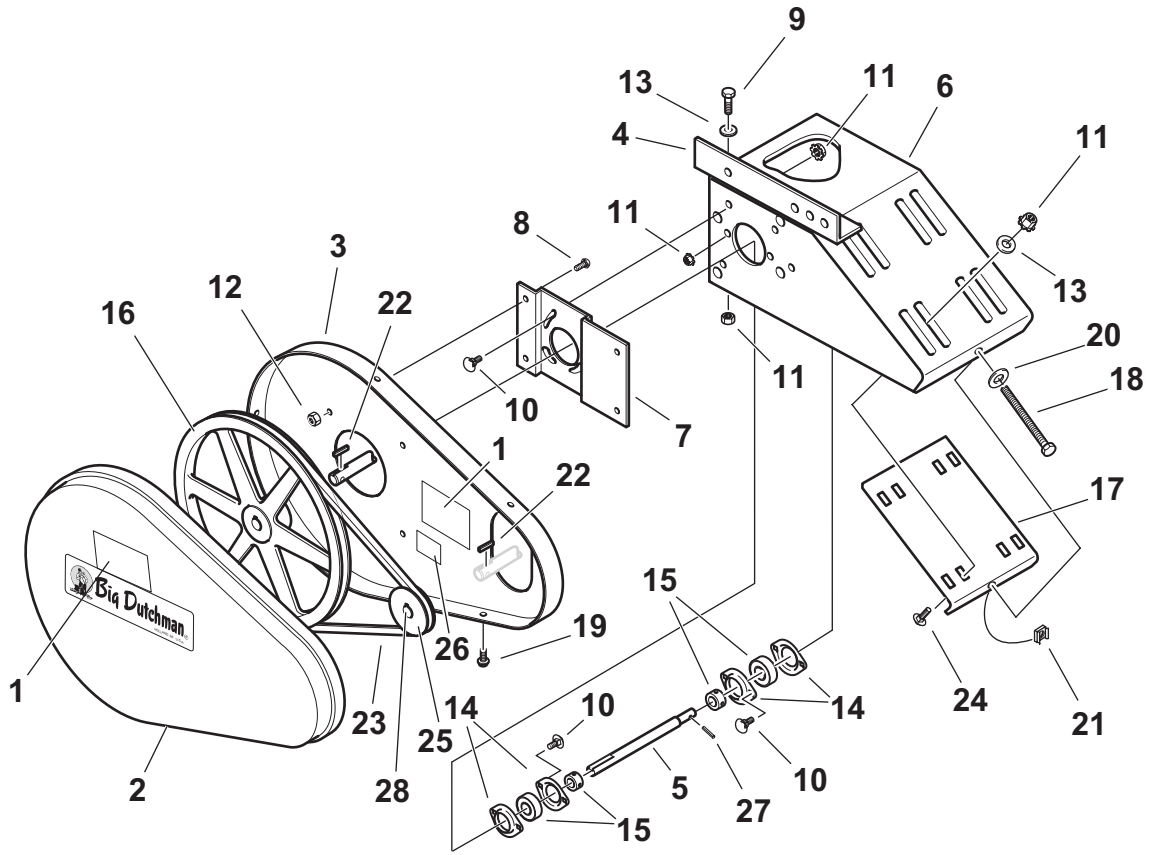

## 4.1 Belt Drive Unit Part No.11-00-0488 Parts List

Item No.	Part No.	Description
1	36-00-0111	Warning Label- Guard
2	11-00-1121	Belt Guard, Front
3	11-00-1122	Belt Guard, Back
4	11-07-1102	Suspension Bracket
5	11-26-0103	Drive Shaft
6	25-03-0142	Motor Mount
7	25-03-0147	Belt Guard Support Plate
8	99-10-0118	Truss Bolt, 10 - 24 x 3/8 in.
9	99-10-0183	Hex Bolt, 5/16 - 18 x 3/4 in.
10	99-10-0449	Carriage Bolt, 5/16 - 18 x 3/4 in.
11	99-20-0100	Kep Nut, 5/16 - 18
12	99-20-1012	Kep Lock Nut, 10 - 24
13	99-21-0003	Flat Washer, 5/16 in.
14	99-50-0667	Bearing Flangette
15	99-50-0980	Bearing and Collar
16	99-50-0981	Type-A Sheave
17	25-03-0146	Motor Mount Slide Plate
18	99-10-0874	Hex Bolt, 3/8 - 16 x 2 1/2 in., FTHD
19	99-10-1115	Screw, 10 x 1/2 in.
20	99-20-0111	Flat Washer, 3/8 in.
21	99-20-0404	Retaining Nut, 3/8 - 16
22	99-50-0020	Square Key, 3/16 x 1 1/4 in.
23	99-54-0047	BELT,V, 4L450
24	99-10-0154	Carriage Bolt, 5/16 - 18 x 1 in.
25	86-00-0212	Type-A Sheave (not included with Belt Drive Unit)
26	00-00-0272	Decal, Inst, Belt Tighten
27	99-50-0174	PIN,ROLL 1/8X1 ZINC PLATED
28	99-10-0582	SCREW SET, 5/16-18 x .25 ALEN

# 5 Control Pan

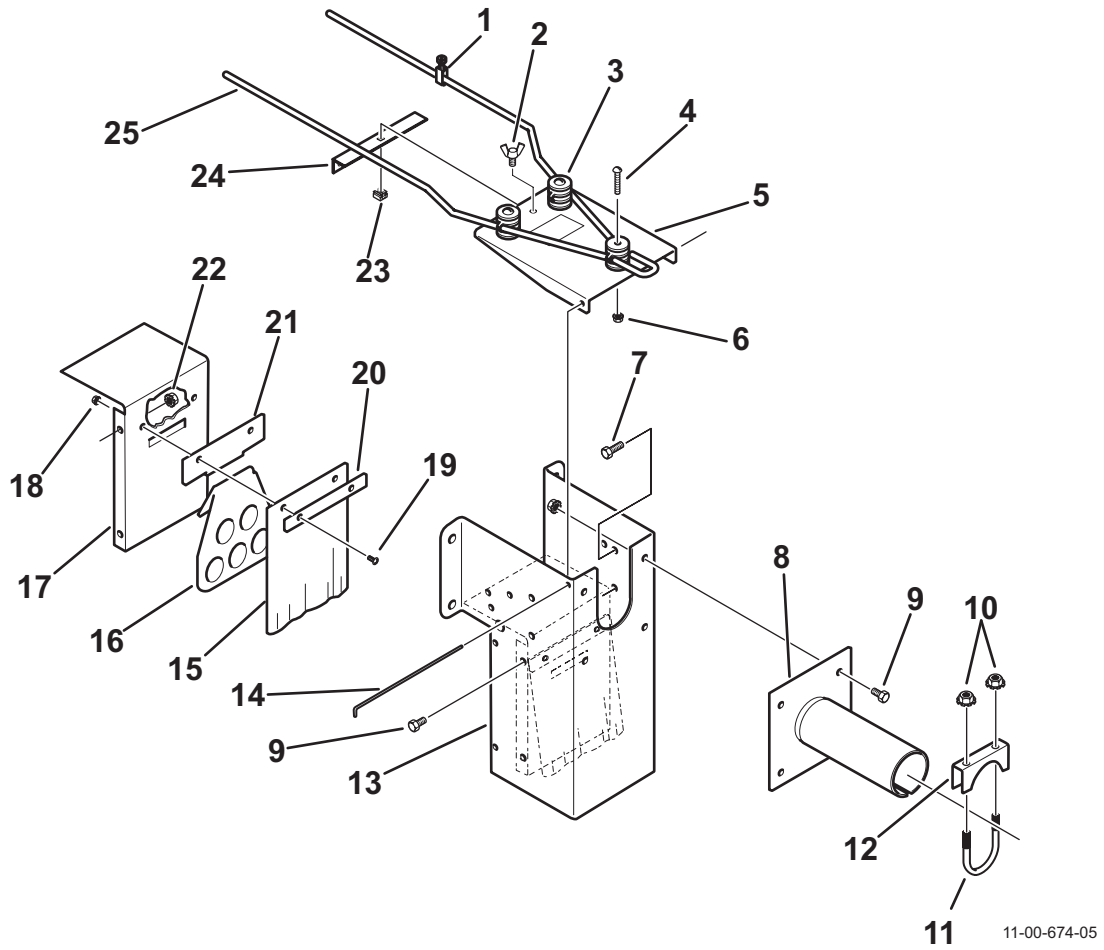

## 5.1 Control Pan Parts List

Item No.	Part No.	Description
1	99-50-0287	Anti Roost Clamp
2	99-10-0110	1/4 - 20 x 1/2 in. Wing Bolt
3	11-00-0307	Insulator
4	99-10-0119	1/4 - 20 x 1 1/8 in. Truss Head Bolt
5	11-00-0327	Cover
6	99-20-0089	10 - 24 Kep Nut
7	99-10-0137	1/4 - 20 x 3/4 in. Hex Bolt
8	11-00-0380	Adapter
9	99-10-0206	1/4 - 20 x 1/2 in. Hex Bolt
10	99-20-0100	5/16 - 18 Kep Nut
11	99-10-1021	5/16 - 18, 2 1/2 in. x 3 in. U Bolt
12	99-50-1039	2 in. U Bolt Clamp
13	11-00-0632	Body
14	11-00-0346	Hinge Wire
15	11-00-0341	Paddle Guard
16	11-00-0727	Drive Unit Paddle
17	11-00-0633	Center Panel
18	99-20-0217	6 - 32 Kep Nut
19	40-00-0964	6 - 32 x 3/8 in. Pan Head Bolt
20	11-00-0329	Paddle Guard Retainer
21	11-00-0332	Paddle Guard Bracket
22	99-20-0047	1/4 - 20 Kep Nut
23	99-20-0224	1/4 - 20 Retaining Nut
24	11-00-0403	Cover Hold Down Angle
25	11-00-0160	Anti Perch Wire

# 5.2 Control Pan (continued)

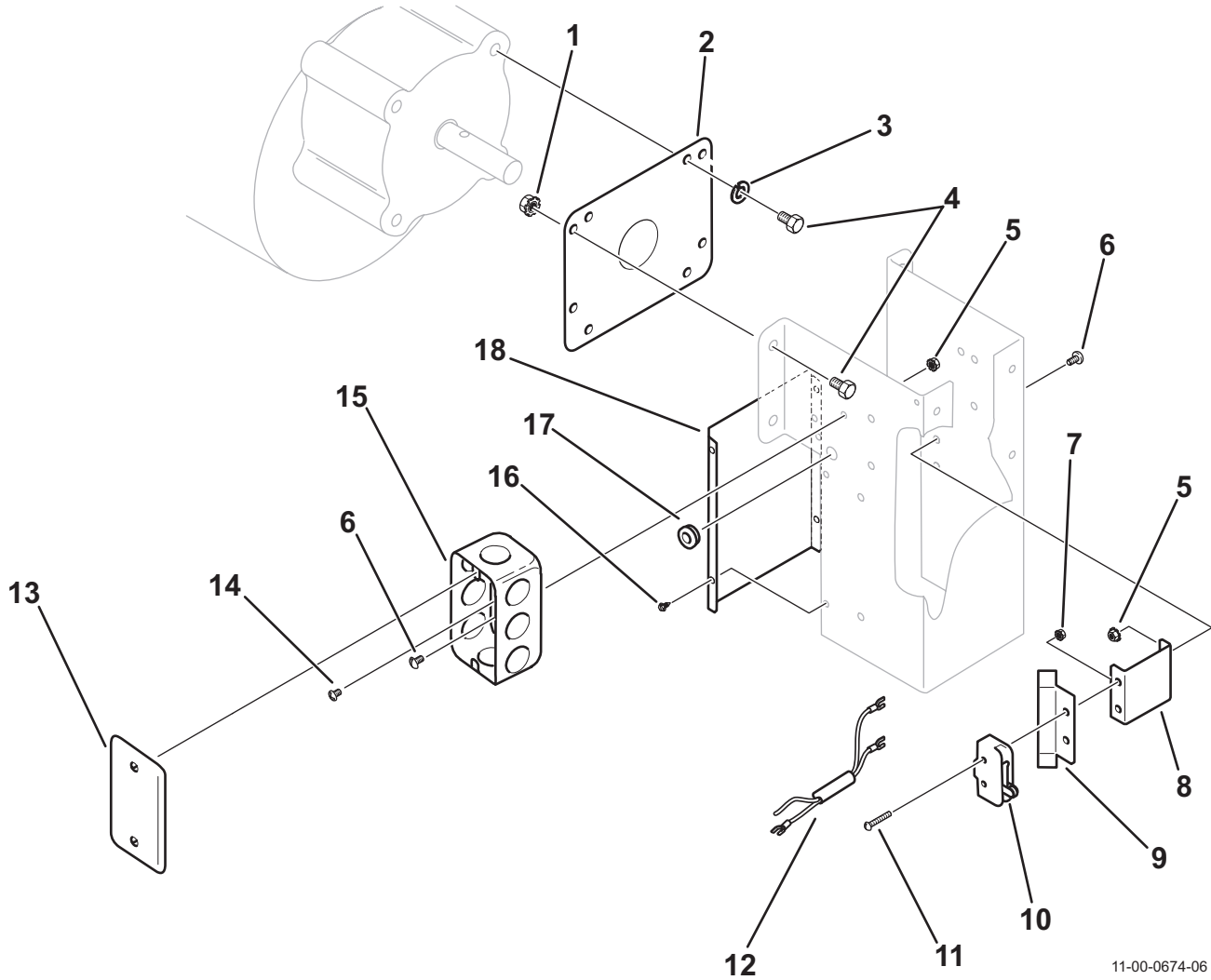

11-00-0674-06

## 5.3 Control Pan Parts List

Item No.	Part No.	Description
1	99-20-0100	5/16 - 18 Kep Nut
2	11-00-0336	Power-Head Flange
3	99-20-0054	5/16 in. Lock Washer
4	99-10-0098	5/16 - 18 x 1/2 in. Hex Bolt
5	99-20-0089	10 - 24 Kep Nut
6	99-10-0118	10 - 24 x 3/8 in. Truss Head Bolt
7	99-20-0217	6 - 32 Kep Nut
8	11-00-0330	Switch Bracket
9	86-00-3878	Switch Insulator
10	92-20-0030	Switch
11	99-10-0654	6 - 32 x 1 in. Round Head Bolt
12	11-00-0450	Switch Wiring Assembly
13	99-30-0188	Conduit Box Cover
14	99-10-0493	10 - 32 x 5/16 in. Pan Head Bolt
15	99-30-0026	Conduit Box
16	99-10-0988	8 x 3/8 in. Sheet Metal Screw
17	99-50-0744	Rubber Grommet
18	11-00-0629	Back Panel

# 5.4 Control Pan (continued)

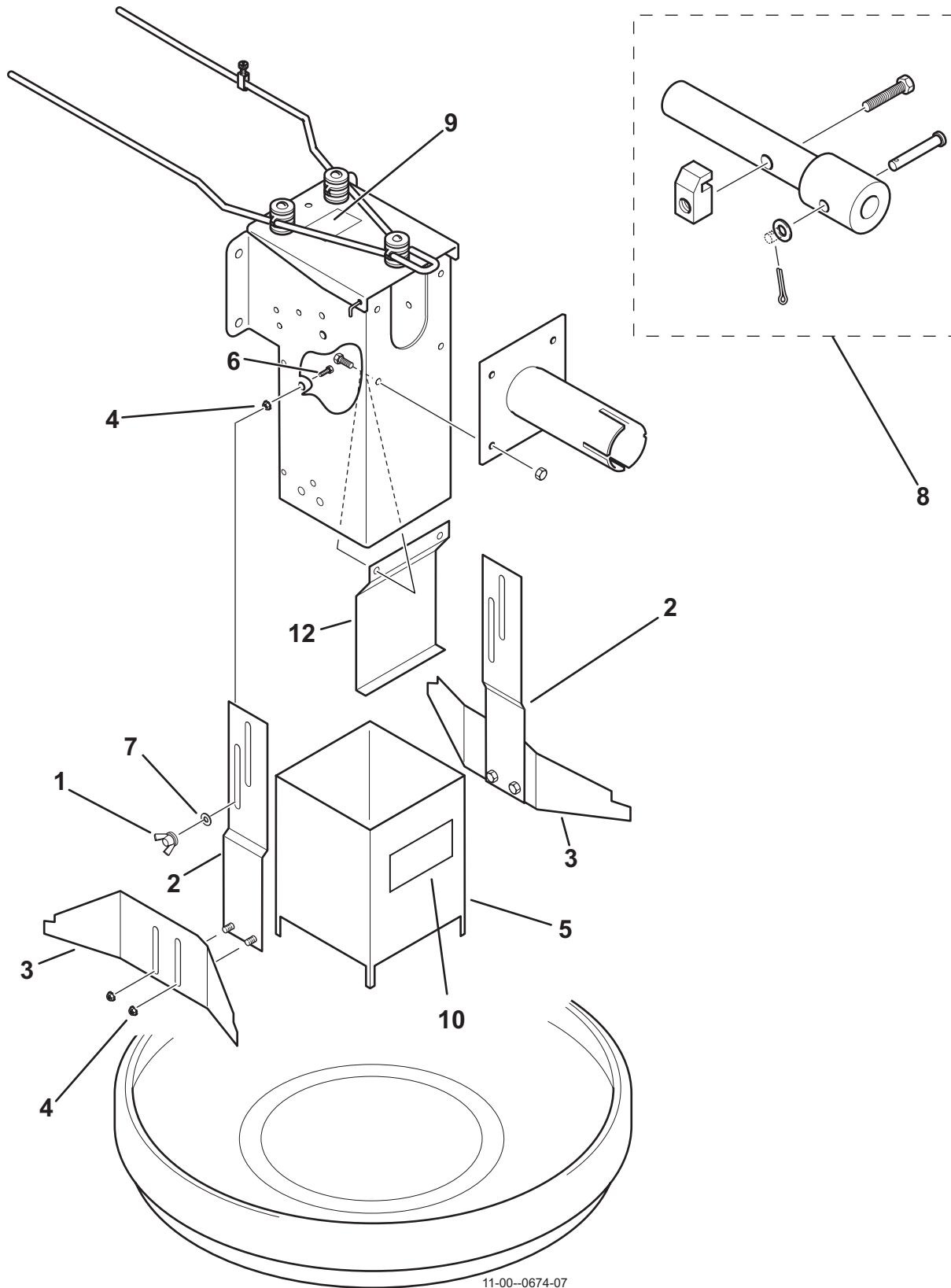

11-00-0674-07

## 5.5 Control Pan (continued)

Item No.	Part No.	Description
1	99-20-0043	1/4 - 20 Wing Nut
2	11-00-0746	Bracket
3	11-00-0747	Control Pan Grille
4	99-20-0047	1/4 - 20 Kep Nut
5	11-00-0628	Feed Restrictor Drop
6	99-10-0137	1/4 - 20 x 3/4 in. Hex Bolt
7	99-20-0336	1/4 in. Washer
8	25-02-1710	Connector Assembly
9	00-00-0436	Caution Decal
10	00-00-0129	Warning Decal
11	11-31-3263	Orange Pan
11	11-17-1121	Blue Pan
12	11-00-0638	Restrictor Plate

## 6 Install Restrictor Plate Steps

Follow these steps to install the Restrictor Plate.

Step 1. Remove pan.

Step 2. Remove bottom bolts and nuts from tube adapter.

Step 3. Install restrictor plate, using existing hardware

Step 4. Replace the Pan.

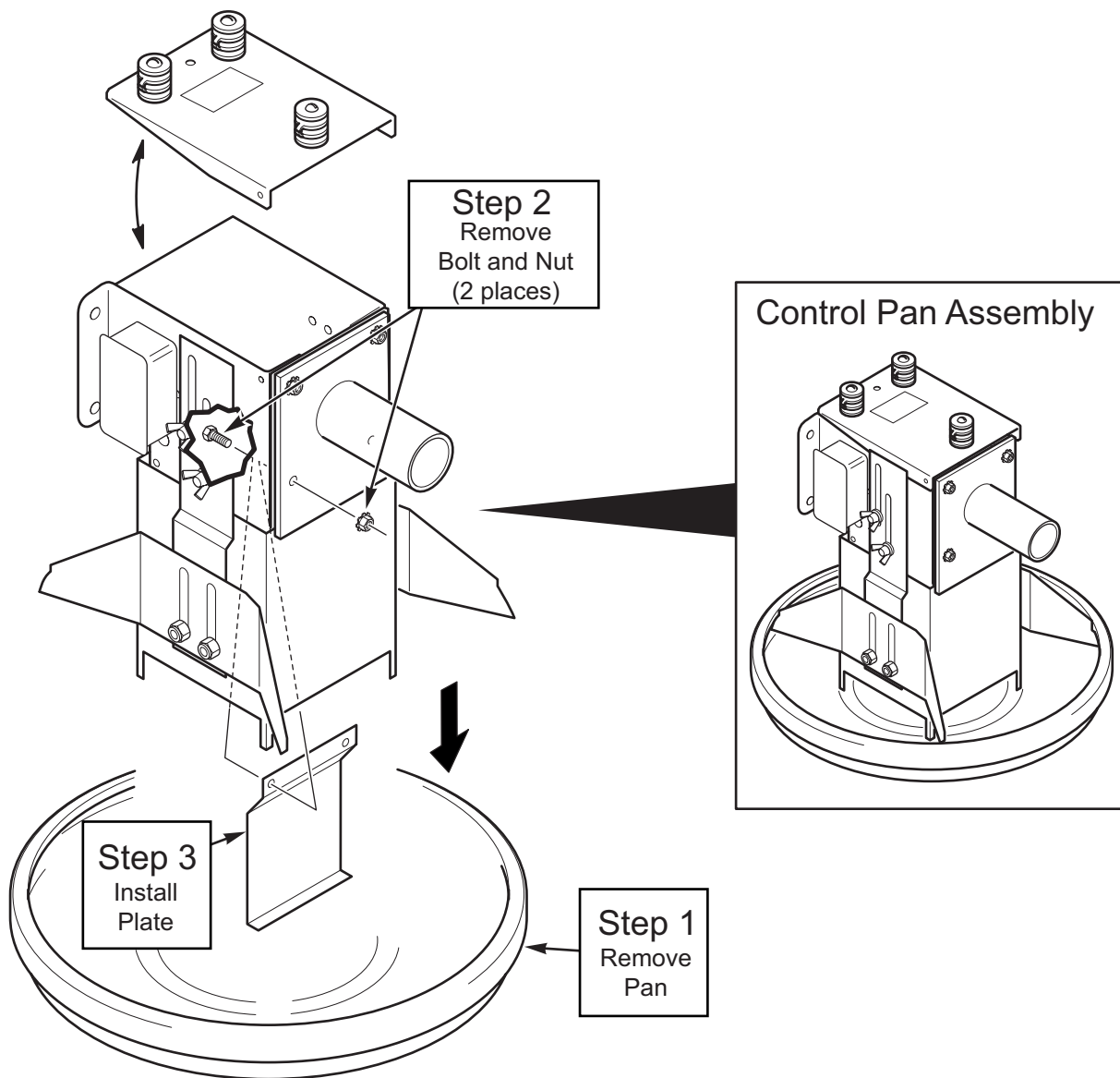

11-00-0674-08



# 7 Intermediate Control Pan Part No. 86-00-2764

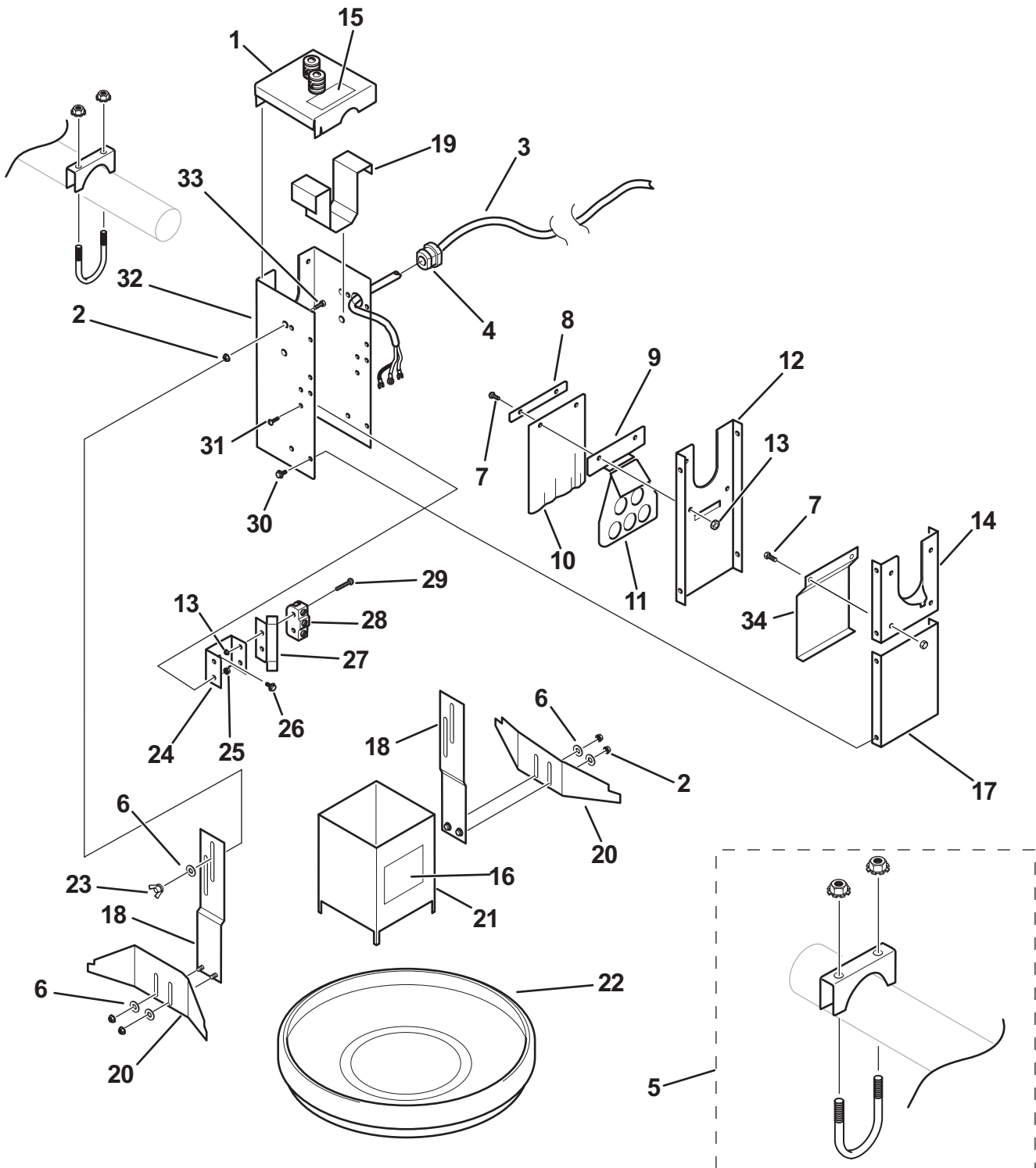

## 7.1 Intermediate Control Pan-Parts List

Item No.	Part No.	Description
1	11-00-0362	Intermediate Lid
2	99-20-0047	1/4 - 20 Kep Nut
3	99-30-1207	Electric Cord
4	99-30-1200	Bushing
5	11-00-1060	Tube Clamp Assy
6	99-20-0336	1/4 in. Washer
7	40-00-0964	6 - 32 x 3/8 in. Slot Head Bolt
8	11-00-0755	Tube Clamp
9	11-00-0332	Paddle Guard
10	11-00-0341	Paddle Guard
11	11-00-0727	Paddle
12	11-00-0356	Panel
13	99-20-0217	6 - 32 Kep Nut
14	11-00-0357	Upper Panel
15	00-00-0436	Caution Decal
16	00-00-0129	Warning Decal
17	11-00-0358	Lower Panel
18	11-00-0746	Bracket
19	11-00-0675	Feed Guard
20	11-00-0747	Control Grill
21	11-00-0628	Feed Restrictor Drop
22	11-31-3263	Pan
23	99-20-0043	1/4 - 20 Wing Nut
24	11-00-0330	Bracket
25	99-20-0089	10 - 24 Kep Lock nut
26	99-10-0493	10 - 32 x 5/16 in. Slot Bolt
27	86-00-3878	Switch Insulator
28	92-20-0030	Micro Switch
29	99-10-0654	6 - 32 x 1 in. RD Head Bolt
30	99-10-0988	8 3/8 in. Sheet Metal Screw
31	99-10-0118	10 - 24 x 3/8 in. Truss Bolt
32	11-00-0355	Intermediate Body
33	99-10-0137	1/4 - 20 x 3/4 in. Hex Bolt
34	11-00-0638	Restrictor Plate

# 8 Fluxx® Intermediate Control Pan

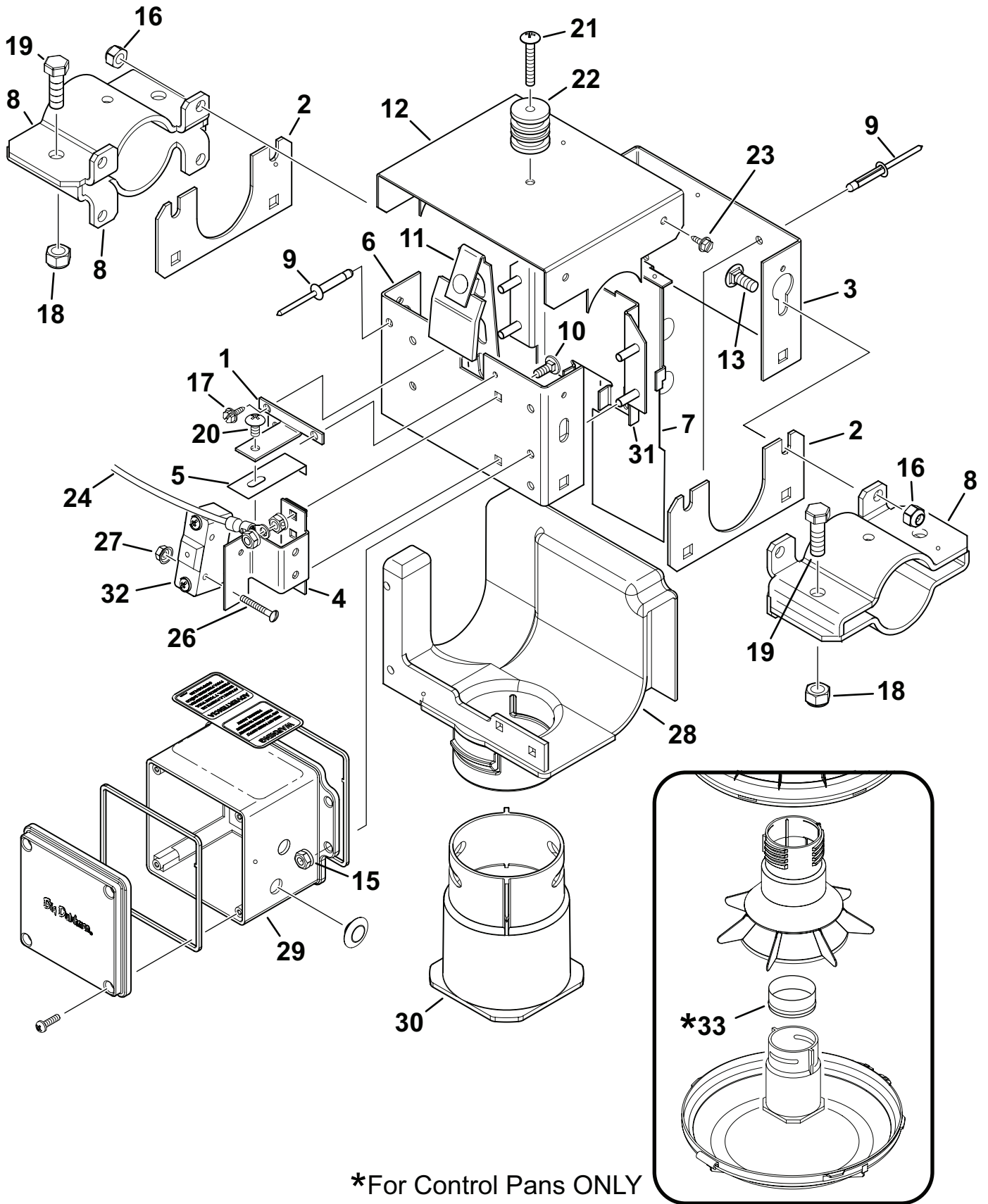

\*For Control Pans ONLY

11-00-0674-10

## 8.1 Fluxx® Intermediate Control Pan Parts List

Item No.	Part No.	Description
1	11-00-0808	Support Bracket, F/Hold Down Bracket
2	11-00-0805	Lower End Flange
3	11-00-0802	Side Panel F/ Internal Mechanical Control Pan
4	11-00-0818	F/Mech, Control Pan, Mechanical Control Pan, Switch Bracket
5	11-00-0806	Hold Down Paddle, F/Bracket
6	11-00-0801	Mech, Control Pan Side, Panel F/Int.
7	11-00-0798	Feed Panel Assembly
8	11-00-0755	Tube Clamp
9	99-10-2001	Pop Rivet, 3/16 x 5/32 15/32 in.
10	99-10-1251	Carriage Bolt, 1/4-20 x 5/8 in. Short Neck
11	11-00-0810	Paddle Assembly
12	11-00-0812	Control Pan F/Intermediate
13	99-10-0195	Carriage Bolt, 1/4-20 c 5/8 in. Short Neck
14	99-20-0030	Flat Washer, #10
15	99-20-0089	10-24 Hex Nylock Lock Nut
16	99-10-0134	1/4-20 Hex Nylock Lock Nut
17	99-10-1316	Hex WashScrew
18	99-20-0176	Hex Lock Nut, 5/16-18
19	99-10-0283	Hex Bolt, 5/16-18 x 1.0 in.
20	99-10-0056	Machine Screw, 10-24 x 3/8 in.
21	99-10-2002	Machine Screw, 10-24 x 1 1/4 in.
22	11-00-0307	Anti-Roost Insulator
23	99-10-0988	Hex Screw, #8 x 3/8 in.
24	00-00-0182	Wire, Elec. 14 MTW, STR, GRN
25	92-40-0909	Wire, Elec. 16 MTW, STR, BLK, (UL), TEW, (CSA)
26	99-10-0654	Machine Screw, 6-32 x 1.0 in.
27	99-20-0217	Kep Lock Nut, 10-24
28	11-00-0815	Bottom, CNTL, Box, F/Fluxx
29	11-00-0822	Elec Box, F/Mech Cntl Pan, Assy
30	83-01-9064	Preliminary Modified Inner Cylinder
31	11-00-0814	Cover F/Paddle, Assembly
32	86-00-3884	SWITCH,MICRO,MAKE FROM 91-CP-1400,WITH 1-5/32" SWITCH ARM
33	11-00-0843	Lower Ring, Inner Cylinder

# 9 Fluxx® End Control Pan

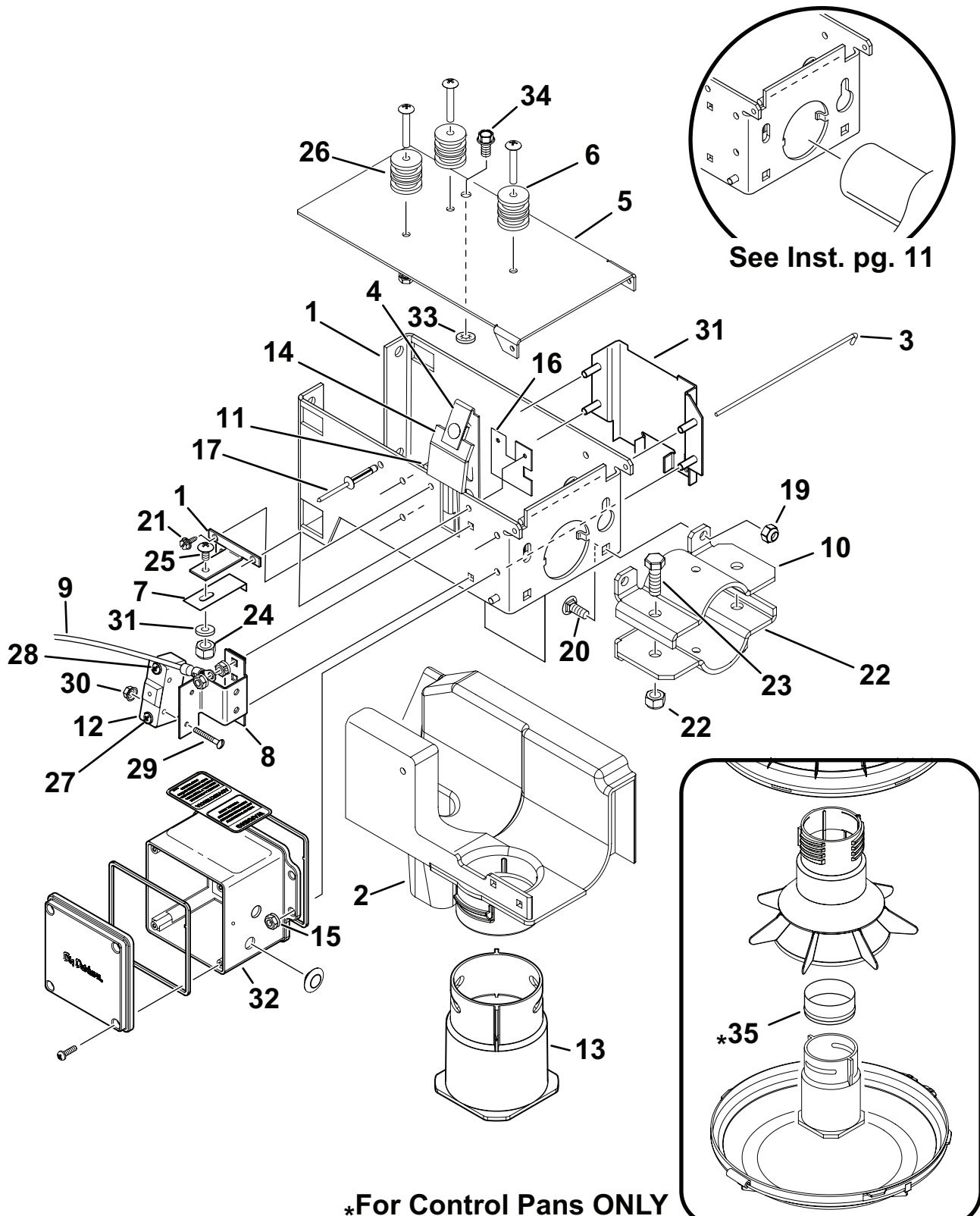

11-00-0674-11

## 9.1 Fluxx® End Control Pan-Parts List

Item No.	Part No.	Description
1	11-00-0793	Housing Control Box
2	86-00-2115	Liner, Plastic F/Control Box
3	11-00-0346	Hinge Wire
4	11-00-0798	Feed Panel Assembly
5	11-00-0792	Control Box Cover, Inj.
6	11-00-0307	Anti-Roost Insulator
7	11-00-0806	Hold Down Paddle, F/Bracket
8	11-00-0807	F/Mech, Control Pan, Mechanical Control Pan
9	00-00-0182	Wire, Elec. 14 MTW, STR, GRN
10	11-00-0755	Tube Clamp
11	11-00-0814	Cover F/Paddle, Assembly
12	86-00-3884	SWITCH,MICRO,MAKE FROM 91-CP-1400,WITH 1-5/32" SWITCH ARM
13	83-01-9064	Preliminary Modified Inner Cylinder
14	11-00-0810	Paddle Assembly
15	11-00-0808	Support bracket, F/Hold Down Bracket
16	11-00-0820	Plate Hinge F/Paddle
17	99-10-2001	Pop rivet, 3/16 x 5/23 15/32 in.
18	99-10-1251	Carriage Bolt, 1/4-20 x 5/8 in. Short Neck
19	99-20-0134	Hex Nylock Lock Nut, 1/4-20
20	99-10-0195	Carriage Bolt, 1/4-20 x 5/8 in. Short Neck
21	99-10-1316	Hex Screw, Washer, #8 x 3/8 in.
22	99-20-0176	Hex Lock Nut, 5/16-18
23	99-10-0283	Hex Head Bolt, 5/16-18 x 1.0 in.
24	99-20-0089	10-24 Hex Nylock Lock Nut
25	99-10-0056	Machine Screw, 10-24 x 3/8 in.
26	99-10-2002	Machine Screw, 10-24 x 1-1/4 in.
27	92-40-0909	Wire, Elec. 16 MTW, STR, BLK, (UL), TEW, (CS)
28	92-40-0909	Elec. Wire, 16MTW, Str. BLK
29	99-10-0654	Machine Screw, 6-32 x 1.0 in.
30	99-20-0217	Kep Lock Nut, 10-24
31	99-20-0030	Flat Washer, #10
32	11-00-0822	Elec Box, F/Mech Control Pan, Assy
33	99-50-8048	1/4 in. Retainer
34	99-50-8049	Hex Screw, Washer, #14 x 1/2 in.
35	11-00-0843	Lower Ring, Inner Cylinder

# 10 One-Way Hopper Part No. 11-01-1133

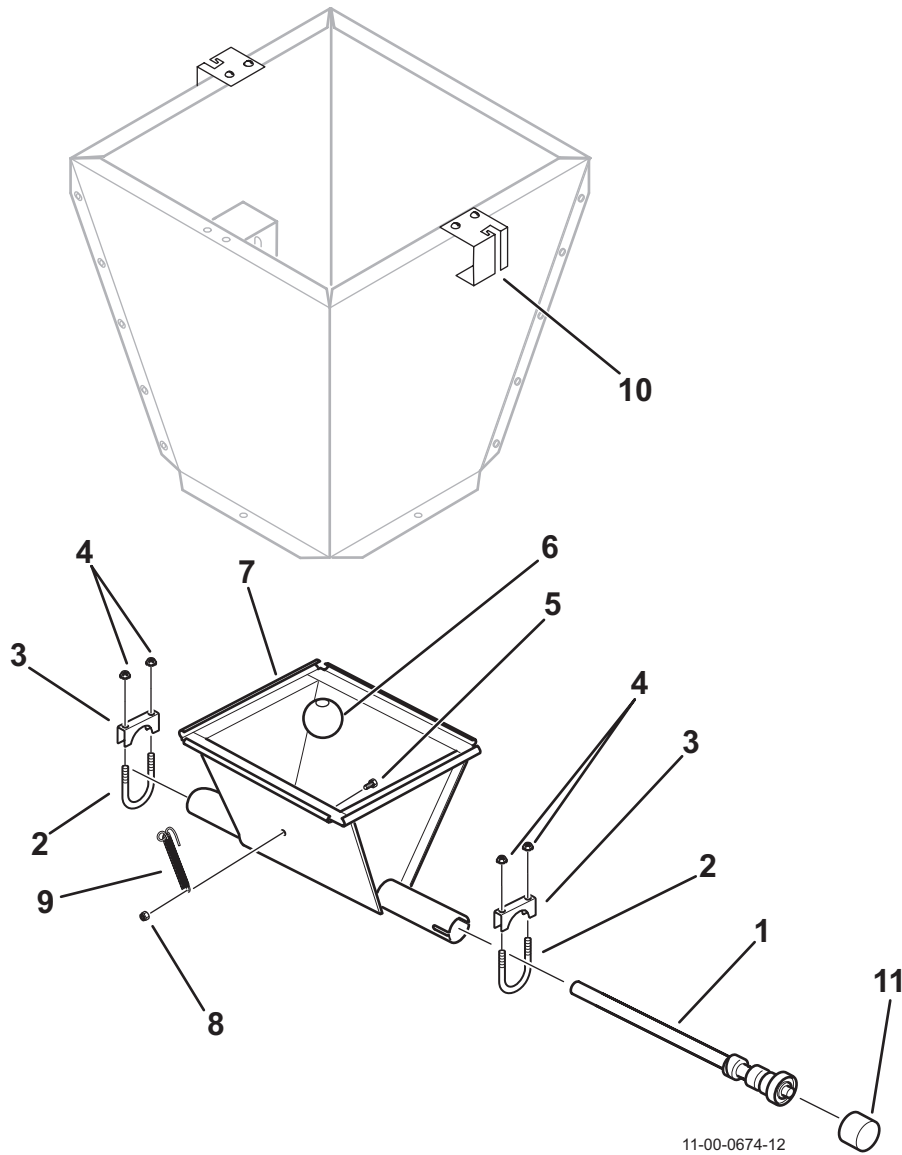

Item No.	Part No.	Description
1	11-00-0753	Arbor Shaft Assembly, 17 in.
2	99-10-1014	5/16 - 18, 2 1/4 in. x 3 in. U Bolt
3	86-00-2525	U Clamp Bracket
4	99-20-0100	5/16 - 18 Kep Nut
5	99-10-0278	5/16 - 18 x 5/8 in. Hex Bolt
6	86-01-4180	Agitator Ball (3" Cast Iron) for FLEXVEY 300/350/450
7	11-01-1329	1-Way Hopper Body
8	99-20-0176	5/16 - 18 Hex Lock Nut
9	11-00-0189	Spring Assembly
10	11-00-0580	Cable Guide Bracket
11	11-00-1056	Arbor Shaft Cap

# 11 Two-Way Hopper Part No. 11-02-1345

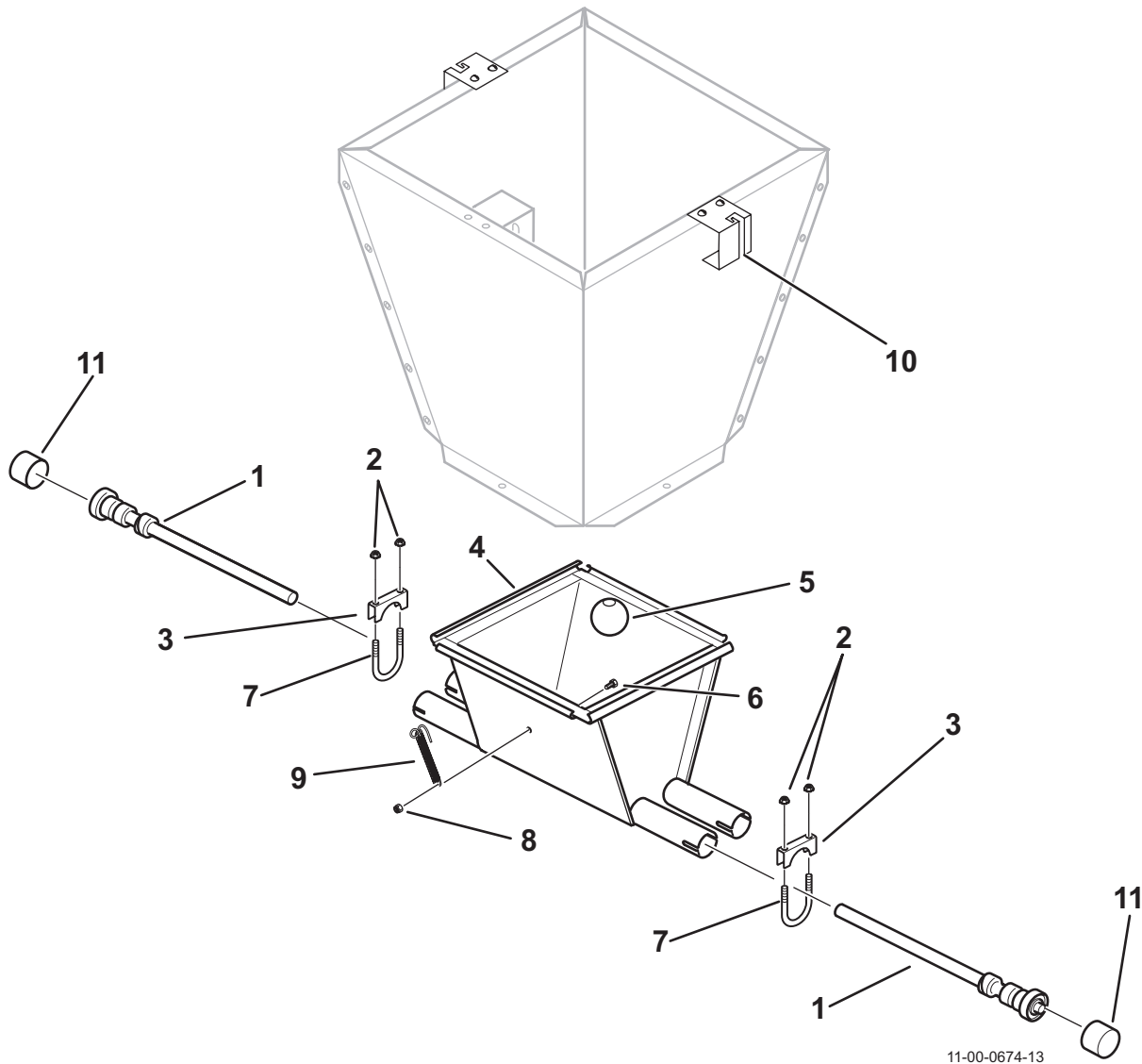

11-00-0674-13

Item No.	Part No.	Description
1	11-00-0753	Arbor Shaft Assembly, 17 in.
2	99-20-0100	5/16 - 18 Kep Nut
3	86-00-2525	U Clamp Bracket
4	11-02-1329	2-Way Hopper Body
5	86-01-4180	Agitator Ball (3" Cast Iron) for FLEXVEY 300/350/450
6	99-10-0278	5/16 - 18 x 5/8 in. Hex Bolt
7	99-10-1014	5/16 - 18, 2 1/4 in. x 3 in. U Bolt
8	99-20-0176	5/16 - 18 Hex Lock Nut
9	11-00-0189	Spring Assembly
10	11-00-0580	Cable Guide Bracket
11	11-00-1056	Arbor Shaft Cap

# 12 Hopper Extension

Part No. 11-00-0575  
80 lb. [36 Kg] Add-On Extension

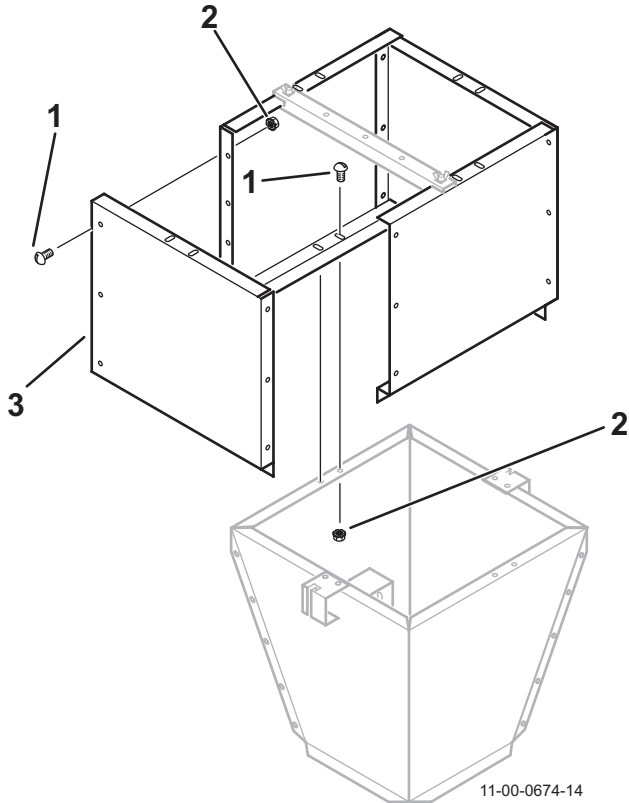

Item	Part No.	Description
1	99-10-0118	#10-24 x 3/8 in. Truss Head Bolt
2	99-20-0089	#10-24 Keps Nut
3	11-00-0576	Side Panel

Part No. 11-00-0786  
250 lb. [113 Kg] Extension

Item	Part No.	Description
1	99-10-0118	SCREW,MACHINE,10-24X3/8 TRUSS HD SLOT ZINC
2	99-20-0089	NUT,10-24 KEP LOCK,NC,ZINC
3	11-00-0774	PANEL SIDE HPR EXT 250#CAP
4	11-00-0609	SUPPORT,DROP TUBE,23.04" HOPPER EXTENSION

Part No. 11-00-0591  
Extension Cover

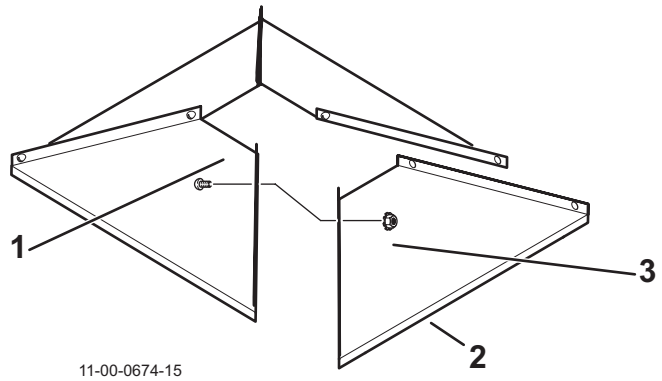

Item	Part No.	Description
1	99-10-0118	Truss Head Bolt
2	10-01-1004	Side Panel
3	99-20-0089	1 - 24 Keps Nut

Part No. 11-00-0573  
100 lb. [45 Kg] Extension

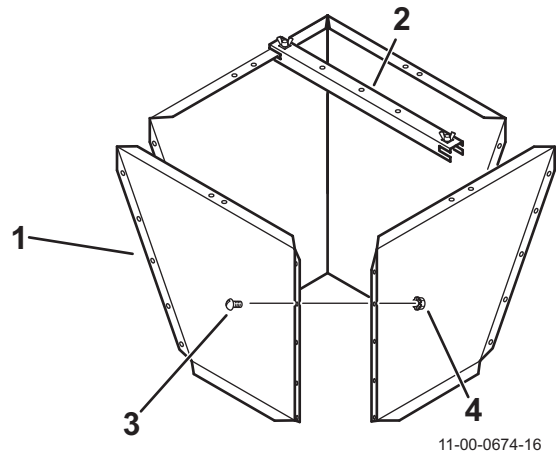

Item	Part No.	Desc.
1	11-00-0574	Side Panel
2	11-00-0584	Drop Tube Support Assembly
3	99-10-0118	10 - 24 x 3/8 in. Truss Head Bolt
4	99-20-0089	10 - 24 Keps Nut

# Index

<b>Part No.</b> .....	<b>Page No.</b>
00-00-0129 .....	15,19
00-00-0182 .....	21,23
00-00-0272 .....	9
00-00-0436 .....	15,19
10-00-9613 .....	4
10-01-1004 .....	26
11-00-0160 .....	11
11-00-0189 .....	24,25
11-00-0307 .....	11,21,23
11-00-0327 .....	11
11-00-0329 .....	11
11-00-0330 .....	13,19
11-00-0332 .....	11,19
11-00-0336 .....	13
11-00-0341 .....	11,19
11-00-0346 .....	11,23
11-00-0355 .....	19
11-00-0356 .....	19
11-00-0357 .....	19
11-00-0358 .....	19
11-00-0362 .....	19
11-00-0380 .....	11
11-00-0403 .....	11
11-00-0450 .....	13
11-00-0488 .....	8,9
11-00-0530 .....	7
11-00-0533 .....	7
11-00-0573 .....	26
11-00-0574 .....	26
11-00-0575 .....	26
11-00-0576 .....	26
11-00-0580 .....	24,25
11-00-0584 .....	26
11-00-0591 .....	26
11-00-0609 .....	26

---

11-00-0628 .....	15,19
11-00-0629 .....	13
11-00-0632 .....	11
11-00-0633 .....	11
11-00-0638 .....	15,19
11-00-0675 .....	19
11-00-0727 .....	11,19
11-00-0746 .....	15,19
11-00-0747 .....	15,19
11-00-0753 .....	24,25
11-00-0755 .....	19,21,23
11-00-0774 .....	26
11-00-0779 .....	7
11-00-0780 .....	7
11-00-0786 .....	26
11-00-0792 .....	23
11-00-0793 .....	23
11-00-0798 .....	21,23
11-00-0801 .....	21
11-00-0802 .....	21
11-00-0805 .....	21
11-00-0806 .....	21,23
11-00-0807 .....	23
11-00-0808 .....	21,23
11-00-0810 .....	21,23
11-00-0812 .....	21
11-00-0814 .....	21,23
11-00-0815 .....	21
11-00-0818 .....	21
11-00-0820 .....	23
11-00-0822 .....	21,23
11-00-0843 .....	21,23
11-00-1023 .....	24,25
11-00-1053 .....	7
11-00-1056 .....	24,25
11-00-1060 .....	19
11-00-1121 .....	9
11-00-1122 .....	9
11-00-9364 .....	7

---

11-01-1133.....	24
11-01-1329.....	24
11-02-1329.....	25
11-02-1345.....	25
11-07-1102.....	9
11-17-1121.....	15
11-26-0103.....	9
11-31-3263.....	15,19
25-02-1710.....	15
25-03-0142.....	9
25-03-0146.....	9
25-03-0147.....	9
36-00-0111.....	9
40-00-0964.....	11,19
83-01-9064.....	21,23
86-00-0205.....	5
86-00-0212.....	9
86-00-2115.....	23
86-00-2525.....	24,25
86-00-2661.....	4,7
86-00-2663.....	5,7
86-00-2764.....	18
86-00-3864.....	4
86-00-3878.....	13,19
86-00-3884.....	21,23
86-01-1050.....	4
86-01-1062.....	5
90-00-0366.....	5
90-00-0449.....	7
90-00-0462.....	7
90-00-0484.....	7
90-00-9069.....	7
90-20-0054.....	4
92-20-0030.....	13,19
92-40-0909.....	21,23
99-10-0056.....	21,23
99-10-0098.....	13
99-10-0109.....	4,5,7
99-10-0110.....	11

---

99-10-0118 .....	9,13,19,26
99-10-0119 .....	11
99-10-0134 .....	21
99-10-0137 .....	11,15,19
99-10-0154 .....	9
99-10-0183 .....	9
99-10-0195 .....	21,23
99-10-0206 .....	11
99-10-0278 .....	24,25
99-10-0283 .....	21,23
99-10-0449 .....	9
99-10-0493 .....	13,19
99-10-0582 .....	9
99-10-0654 .....	13,19,21,23
99-10-0874 .....	9
99-10-0988 .....	13,19,21
99-10-1014 .....	24,25
99-10-1021 .....	11
99-10-1115 .....	9
99-10-1216 .....	7
99-10-1251 .....	21,23
99-10-1316 .....	21,23
99-10-2001 .....	21,23
99-10-2002 .....	21,23
99-20-0030 .....	21,23
99-20-0043 .....	15,19
99-20-0047 .....	11,15,19
99-20-0054 .....	5,7,13
99-20-0089 .....	11,13,19,21,23,26
99-20-0100 .....	9,11,13,24,25
99-20-0111 .....	9
99-20-0134 .....	23
99-20-0176 .....	21,23,24,25
99-20-0217 .....	11,13,19,21,23
99-20-0224 .....	11
99-20-0336 .....	15,19
99-20-0404 .....	9
99-20-1012 .....	9
99-21-0003 .....	9

99-30-0026 .....	13
99-30-0188 .....	13
99-30-1200 .....	19
99-30-1207 .....	19
99-50-0020 .....	9
99-50-0174 .....	9
99-50-0287 .....	11
99-50-0338 .....	7
99-50-0667 .....	9
99-50-0744 .....	13
99-50-0980 .....	9
99-50-0981 .....	9
99-50-1039 .....	11
99-50-8048 .....	23
99-50-8049 .....	23
99-54-0047 .....	9

## Big Dutchman, Inc. Limited Warranty

Big Dutchman, Inc. (“**Big Dutchman**”) warrants to original purchaser (“**Buyer**”) that goods manufactured solely by Big Dutchman (“**Products**”) will be free from defects in material or workmanship under normal and intended use and service for a period of one year from delivery date of the Products except that the Products shall not be defective to the extent that (i) they conform with drawings of or specifications for or a sample of goods that have been approved by Buyer; (ii) they conform with goods, testing results, dimensional layouts or manufacturing methods that have been submitted and approved by Buyer; (iii) they are damaged due to the method or length of storage by Buyer; or (iv) to the extent they conform to the specifications as changed or waived if Buyer’s representative agrees, either orally or in writing, to the change in or waiver of the specifications for any Product.

In the event of a defect in any Products constituting a breach of the warranty provided herein, Big Dutchman will at its option either (i) repair or replace such Product free of charge, or (ii) in lieu of repair or replacement, refund to Buyer the original purchase price less the reasonable value of Buyer’s use of the Products. Big Dutchman shall furnish to Buyer instructions for the disposition of the defective goods. Big Dutchman shall have the option of requiring the return of the defective goods, transportation prepaid, and proof that the goods were not used, installed or altered or subject to misuse or abuse to establish the claim. No goods shall be returned to Big Dutchman without its prior consent. The acceptance of any goods returned to Big Dutchman shall not be deemed an admission that the goods are defective or in breach of any warranty, and if Big Dutchman determines that the goods are not defective they may be returned to Buyer at Buyer’s expense. This warranty sets forth Buyer’s sole and exclusive remedies for any defect in the goods. The rights and obligation under this warranty may not be assigned or delegated to a third party by Buyer without the prior written permission of Big Dutchman. Neither Buyer nor any other person may modify or expand the warranty provided herein, waive any of the limitations, or make any different or additional warranties with respect to the Products. Any statements to the contrary are hereby rendered null and void unless expressly agreed to in writing by an authorized officer of Big Dutchman.

EXCEPT AS STATED IN ABOVE, BIG DUTCHMAN DOES NOT MAKE ANY WARRANTY AS TO THE GOODS OR SERVICES AND, IN PARTICULAR, DOES NOT MAKE ANY WARRANTY OF MERCHANTABILITY OR FITNESS FOR ANY PARTICULAR PURPOSE, AND BUYER IS SOLELY RESPONSIBLE FOR DETERMINING THE PROPER APPLICATION AND USE OF THE GOODS.

Big Dutchman makes no representation or warranty that individual animals, or any given population of animals, will utilize any of Big Dutchman’s goods in the manner for which the goods were intended or designated. Any component parts that are not manufactured by Big Dutchman, such as electrical motors and controls, are excluded from any warrant by Big Dutchman, although such parts may be covered by separate warranties of the respective manufacturers. This warranty set forth above does not apply if all components of a system are not supplied by Big Dutchman or if the goods are not purchased from and installed by an authorized distributor or company warehouse, or installed and operated in accordance with Big Dutchman’s specifications and instructions.

BIG DUTCHMAN SHALL NOT HAVE ANY TORT LIABILITY TO BUYER OR ANY OTHER PERSON WITH RESPECT TO ANY OF THE GOODS OR SERVICES AND SHALL NOT BE LIABLE FOR CONSEQUENTIAL, INCIDENTAL, SPECIAL, EXEMPLARY, INDIRECT OR PUNITIVE DAMAGES ARISING FROM ANY PRODUCT DEFECT, DELAY, NONDELIVERY, RECALL OR OTHER BREACH. BUYER SHALL NOT HAVE ANY RIGHT OF REJECTION OR OF REVOCATION OF ACCEPTANCE OF THE GOODS.



**Big Dutchman**®

USA

P.O. Box 1017 · Holland, MI 49422-1017 · USA

tel + 1 616 582 4000 fax + 1 616 392 6188

www.bigdutchmanusa.com · bigd@bigdutchmanusa.com